



SW SERIES

PORTION CONTROL SCALE



SW-N Model - Non-NTEP version
Includes LB:OZ Decimal and LB:OZ Fractional Modes

CAS
S • C • A • L • E



SW Series PORTION CONTROL Scale

Features

The SW Series Bench Scale is a well built, sturdy scale that will stand up to years of use. Available in two styles, the legal for trade SW and the SW-N. The SW-N adds the lb:oz fraction and lb:oz decimal modes.

- Battery Operated with Auto Power Off
- Large Easy to Read 1 Inch LCD Display
- Lb/g/kg/oz Switchable
- Lb:oz decimal & lb:oz fraction (SW-N)
- Soft Touch Tack Switch
- Compact Design & Stainless Steel Platter
- Optional Rear Display
- Legal for Trade/COC #: 99-002 (excluding SW-N)

Specifications

Model		SW-5	SW-10	SW-20	SW-50
Weighing Capacity	lb	5 x 0.002 lb	10 x 0.005 lb	20 x 0.01 lb	50 x 0.02 lb
	oz	80 x 0.05 oz	160 x 0.1 oz	400 x 0.2 oz	800 x 0.5 oz
	kg	2 x 0.001 kg	5 x 0.002 kg	10 x 0.005 kg	20 x 0.01 kg
	g	2000 x 1 g	5000 x 2 g	10000 x 5 g	20000 x 10 g
	SW-N Only (Not Legal for Trade)				
	lb:oz dec	5 lb x 0.05 oz	10 lb x 0.1 oz	20 lb x 0.2 oz	50 lb x 0.5 oz
	lb:oz frac	5 lb x 1/16 oz	10 lb x 1/8 oz	20 lb x 1/4 oz	50 lb x 1/2 oz
Display Digit	5 Digit LCD (1 Inch)				
Display Designators	Stable, Zero, Net, Batt				
Keys	Zero, Tare, Unit, Power				
Measurement Type	Load Cell				
Power Source	DC 9V (1.5V x 6 ea) / AC Adapter Included				
Power Consumption	0.25 W				
Operating Time	Alkaline Dry Battery: 1000 hr / Mn Battery: 500 hr				
Operating Temp	-10°C - 40°C / 14°F - 104°F				
Platter Size (in/mm)	9.05(W) x 7.48 (D) / 230 (W) x 190 (D)				
Dimensions (inch/mm)	10.23 (W) x 11.29 (D) x 5.39 (H)				
	260 (W) x 287 (D) x 137 (H)				
Product Weight	6.92 lbs / 3.14 kg				

Display Modes



Lb - SW & SW-N



Kg - SW & SW-N



Oz - SW only



Lb:oz decimal - SW-N only



Grams - SW & SW-N



Lb:oz fraction - SW-N only

Options

- Rear Display
- Full Body Protective Cover (included w/scale)



Dimensions

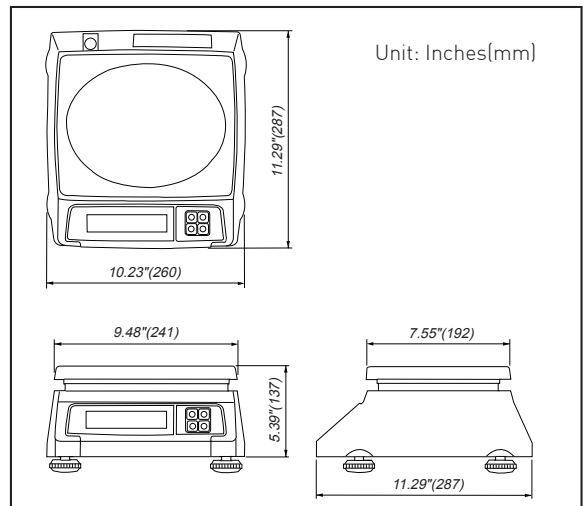

CAS USA Corporation Corporate Office

99 Murray Hill Parkway
East Rutherford, NJ 07073
Tel: (201) 933-9002
Fax: (201) 933-9025
<http://www.cas-usa.com>

