

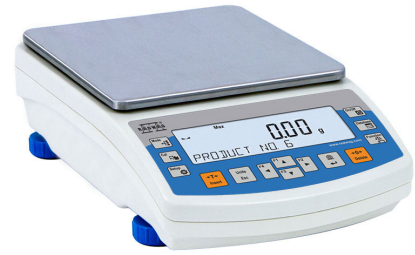

More information on the website
radwag.com/en/info,w1,NTZ

PS 10100.R2.M Precision Balance, PS 8100.R2.M Precision Balance, PS 6100.R2.M Precision Balance, PS 2100.R2.M Precision Balance, PS 600.R2 Precision Balance, PS 3500.R2.M Precision Balance, PS 0.6.R2 Precision Balance, PS 4500.R2.M Precision Balance, PS 750.R2 Precision Balance, PS 200/2000.R2 Precision Balance, PS 1000.R2 Precision Balance, PS 210.R2 Precision Balance, PS 360.R2 Precision Balance



PS 10100.R2.M Precision Balance
PS 8100.R2.M Precision Balance
PS 6100.R2.M Precision Balance
PS 2100.R2.M Precision Balance
PS 3500.R2.M Precision Balance
PS 4500.R2.M Precision Balance

PS 600.R2 Precision Balance
PS 750.R2 Precision Balance
PS 200/2000.R2 Precision Balance
PS 1000.R2 Precision Balance
PS 210.R2 Precision Balance
PS 360.R2 Precision Balance

PS 0.6.R2 Precision Balance

The drawings, photos and graphics used are for illustrative purposes only.

Functions



Autotest



Dosing



Percent Weighing



Totalizing



Parts counting



Peak hold



Newton unit measurement



Statistics



Checkweighing



GLP Procedures



Animal weighing



Density determination

Datasheet

	PS 200/2000.R2 Precision Balance	PS 210.R2 Precision Balance	PS 360.R2 Precision Balance
Metrological parameters			
Maximum capacity [Max]	200 / 2000 g	210 g	360 g
Minimum load	20 mg	20 mg	20 mg
Readability [d]	0,001 / 0,01 g	0,001 g	0,001 g
Verification scale interval [e]	0,01/0,1 g	0,01 g	0,01 g
Tare range	-2000 g	-210 g	-360 g
Minimum weight (USP)	—	—	—
Minimum weight (U=1%,k=2)			
Repeatability (Max)	0,001 / 0,01 g	0,001 g	0,001 g
Repeatability (5% Max)	0,0005 / 0,005 g	0,0005 g	0,0005 g
Linearity	±0,002 / 0,02 g	±0,002 g	±0,002 g
Stabilization time	2 / 1,5 s	2 s	2 s
Adjustment	internal (automatic)	internal (automatic)	internal (automatic)
OIML Class	II	II	II
Physical parameters			
Leveling system	manual	manual	manual
Display	LCD (backlit)	LCD (backlit)	LCD (backlit)
Protection class	IP 43	IP 43	IP 43
Delivery components	Balance, weighing pan, weighing pan shield, grounding bumper ×1, bumper ×3, power supply.	Balance, weighing pan, weighing pan shield, grounding bumper ×1, bumper ×3, power supply.	Balance, weighing pan, weighing pan shield, grounding bumper ×1, bumper ×3, power supply.
Weighing pan dimensions	128×128 mm	128×128 mm	128×128 mm
Device dimensions	—	—	—
Packaging dimensions	370×290×465 mm	470×380×336 mm	470×380×336 mm
Net weight	3,9 kg	3,7 kg	3,7 kg
Gross weight	6 kg	5,3 kg	5,3 kg
Communication interface			
Communication interface	2×RS232 ¹ , USB-A, USB-B, Wi-Fi (option)	2×RS232 ¹ , USB-A, USB-B, Wi-Fi (option)	2×RS232 ¹ , USB-A, USB-B, Wi-Fi (option)
Electrical parameters			
Power supply	Adapter: 100 – 240V AC 50/60Hz 0,6A; 12V DC 1,2A Balance: 12 – 15V DC 0,4A max	Adapter: 100 – 240V AC 50/60Hz 0,6A; 12V DC 1,2A Balance: 12 – 15V DC 0,4A max	Adapter: 100 – 240V AC 50/60Hz 0,6A; 12V DC 1,2A Balance: 12 – 15V DC 0,4A max
Environmental conditions			
Operating temperature	+10 ÷ +40 °C	+10 ÷ +40 °C	+10 ÷ +40 °C
Storage temperature	—	—	—
Relative humidity			

Repeatability is expressed as a standard deviation from 10 weighing cycles. Stabilization time depends on the ambient conditions and the dynamics of weighing pan loading; specified for FAST profile. 1 Barcode scanners, available as weighing instrument accessory, communicate with the instrument via RS232 interface exclusively.

Datasheet

	PS 600.R2 Precision Balance	PS 0.6.R2 Precision Balance	PS 750.R2 Precision Balance
Metrological parameters			
Maximum capacity [Max]	600 g	600 g	750 g
Minimum load	20 mg	500 mg	20 mg
Readability [d]	0,001 g	0,01 g	0,001 g
Verification scale interval [e]	0,01 g	0,01 g	0,01 g
Tare range	-600 g	-600 g	-750 g
Minimum weight (USP)	–	–	–
Minimum weight (U=1%,k=2)			
Repeatability (Max)	0,0015 g	0,01 g	0,0015 g
Repeatability (5% Max)	0,0005 g	0,005 g	0,0005 g
Linearity	±0,003 g	±0,02 g	±0,003 g
Stabilization time	2 s	1,5 s	2 s
Adjustment	internal (automatic)	internal (automatic)	internal (automatic)
OIML Class	II	II	II
Physical parameters			
Leveling system	manual	manual	manual
Display	LCD (backlit)	LCD (backlit)	LCD (backlit)
Protection class	IP 43	IP 43	IP 43
Delivery components	Balance, weighing pan, weighing pan shield, grounding bumper ×1, bumper ×3, power supply.	Balance, weighing pan, weighing pan shield, grounding bumper ×1, bumper ×3, power supply.	Balance, weighing pan, weighing pan shield, grounding bumper ×1, bumper ×3, power supply.
Weighing pan dimensions	128×128 mm	195×195 mm	128×128 mm
Device dimensions	–	–	–
Packaging dimensions	470×380×336 mm	470×380×336 mm	470×380×336 mm
Net weight	3,9 kg	3,9 kg	3,9 kg
Gross weight	5,5 kg	5,5 kg	5,5 kg
Communication interface			
Communication interface	2×RS232 ¹ , USB-A, USB-B, Wi-Fi (option)	2×RS232 ¹ , USB-A, USB-B, Wi-Fi (option)	2×RS232 ¹ , USB-A, USB-B, Wi-Fi (option)
Electrical parameters			
Power supply	Adapter: 100 – 240V AC 50/60Hz 0,6A; 12V DC 1,2A Balance: 12 – 15V DC 0,4A max	Adapter: 100 – 240V AC 50/60Hz 0,6A; 12V DC 1,2A Balance: 12 – 15V DC 0,4A max	Adapter: 100 – 240V AC 50/60Hz 0,6A; 12V DC 1,2A Balance: 12 – 15V DC 0,4A max
Environmental conditions			
Operating temperature	+10 ÷ +40 °C	+10 ÷ +40 °C	+10 ÷ +40 °C
Storage temperature	–	–	–
Relative humidity			

Repeatability is expressed as a standard deviation from 10 weighing cycles. Stabilization time depends on the ambient conditions and the dynamics of weighing pan loading; specified for FAST profile. 1 Barcode scanners, available as weighing instrument accessory, communicate with the instrument via RS232 interface exclusively.

Datasheet

	PS 1000.R2 Precision Balance	PS 2100.R2.M Precision Balance	PS 3500.R2.M Precision Balance
Metrological parameters			
Maximum capacity [Max]	1000 g	2100 g	3500 g
Minimum load	20 mg	500 mg	500 mg
Readability [d]	0,001 g	0,01 g	0,01 g
Verification scale interval [e]	0,01 g	0,1 g	0,1 g
Tare range	-1000 g	-2100 g	-3500 g
Minimum weight (USP)	—	—	—
Minimum weight (U=1%,k=2)			
Repeatability (Max)	0,0015 g	0,008 g	0,008 g
Repeatability (5% Max)	0,0005 g	0,005 g	0,005 g
Linearity	±0,003 g	±0,02 g	±0,02 g
Stabilization time	2 s	1,5 s	1,5 s
Adjustment	internal (automatic)	internal (automatic)	internal (automatic)
OIML Class	II	II	II
Physical parameters			
Leveling system	manual	manual	manual
Display	LCD (backlit)	LCD (backlit)	LCD (backlit)
Protection class	IP 43	IP 43	IP 43
Delivery components	Balance, weighing pan, weighing pan shield, grounding bumper x1, bumper x3, power supply.	Balance, weighing pan, weighing pan shield, power supply	Balance, weighing pan, weighing pan shield, power supply
Weighing pan dimensions	128×128 mm	195×195 mm	195×195 mm
Device dimensions	—	—	—
Packaging dimensions	470×380×336 mm	370×290×465 mm	470×380×336 mm
Net weight	3,9 kg	4,3 kg	4,5 kg
Gross weight	5,5 kg	5,8 kg	6 kg
Communication interface			
Communication interface	2×RS232 ¹ , USB-A, USB-B, Wi-Fi (option)	2×RS232 ¹ , USB-A, USB-B, Wi-Fi (option)	2×RS232 ¹ , USB-A, USB-B, Wi-Fi (option)
Electrical parameters			
Power supply	Adapter: 100 – 240V AC 50/60Hz 0,6A; 12V DC 1,2A Balance: 12 – 15V DC 0,4A max	Adapter: 100 – 240V AC 50/60Hz 0,6A; 12V DC 1,2A Balance: 12 – 15V DC 0,4A max	Adapter: 100 – 240V AC 50/60Hz 0,6A; 12V DC 1,2A Balance: 12 – 15V DC 0,4A max
Environmental conditions			
Operating temperature	+10 ÷ +40 °C	+10 ÷ +40 °C	+10 ÷ +40 °C
Storage temperature	—	—	—
Relative humidity			

Repeatability is expressed as a standard deviation from 10 weighing cycles. Stabilization time depends on the ambient conditions and the dynamics of weighing pan loading; specified for FAST profile. 1 Barcode scanners, available as weighing instrument accessory, communicate with the instrument via RS232 interface exclusively.

Datasheet

	PS 4500.R2.M Precision Balance	PS 6100.R2.M Precision Balance	PS 8100.R2.M Precision Balance
Metrological parameters			
Maximum capacity [Max]	4500 g	6100 g	8100 g
Minimum load	0,5 g	0,5 g	0,5 g
Readability [d]	0,01 g	0,01 g	0,01 g
Verification scale interval [e]	0,1 g	0,1 g	0,1 g
Tare range	-4500 g	-6100 g	-8100 g
Minimum weight (USP)	10 g	10 g	10 g
Minimum weight (U=1%,k=2)	1 g	1 g	1 g
Repeatability (Max)	0,008 g	0,008 g	0,01 g
Repeatability (5% Max)	0,005 g	0,005 g	0,005 g
Linearity	±0,02 g	±0,02 g	±0,02 g
Stabilization time	1,5 s	1,5 s	1,5 s
Adjustment	internal (automatic)	internal (automatic)	internal (automatic)
OIML Class	II	II	II
Physical parameters			
Leveling system	manual	manual	manual
Display	LCD (backlit)	LCD (backlit)	LCD (backlit)
Protection class	IP 43	IP 43	IP 43
Delivery components	Balance, weighing pan, weighing pan shield, power supply	Balance, weighing pan, weighing pan shield, power supply	Balance, weighing pan, weighing pan shield, power supply
Weighing pan dimensions	195×195 mm	195×195 mm	195×195 mm
Device dimensions	333×206×107 mm	333×206×107 mm	333×206×107 mm
Packaging dimensions	470×380×336 mm	470×380×336 mm	370×290×465 mm
Net weight	4,5 kg	4,5 kg	4,5 kg
Gross weight	6,1 kg	6,1 kg	6,1 kg
Communication interface			
Communication interface	2×RS232 ¹ , USB-A, USB-B, Wi-Fi (option)	2×RS232 ¹ , USB-A, USB-B, Wi-Fi (option)	2×RS232 ¹ , USB-A, USB-B, Wi-Fi (option)
Electrical parameters			
Power supply	Adapter: 100 – 240V AC 50/60Hz 0,6A; 12V DC 1,2A Balance: 12 – 15V DC 0,4A max	Adapter: 100 – 240V AC 50/60Hz 0,6A; 12V DC 1,2A Balance: 12 – 15V DC 0,4A max	Adapter: 100 – 240V AC 50/60Hz 0,6A; 12V DC 1,2A Balance: 12 – 15V DC 0,4A max
Environmental conditions			
Operating temperature	+10 ÷ +40 °C	+10 ÷ +40 °C	+10 ÷ +40 °C
Storage temperature	-20 ÷ +50 °C	-20 ÷ +50 °C	-20 ÷ +50 °C
Relative humidity		40% ÷ 80%	40% ÷ 80%

Repeatability is expressed as a standard deviation from 10 weighing cycles. Stabilization time depends on the ambient conditions and the dynamics of weighing pan loading; specified for FAST profile. 1 Barcode scanners, available as weighing instrument accessory, communicate with the instrument via RS232 interface exclusively.

Datasheet

	PS 10100.R2.M Precision Balance
Metrological parameters	
Maximum capacity [Max]	10100 g
Minimum load	0,5 g
Readability [d]	0,01 g
Verification scale interval [e]	-
Tare range	-10100 g
Minimum weight (USP)	10 g
Minimum weight (U=1%,k=2)	1 g
Repeatability (Max)	0,012 g
Repeatability (5% Max)	0,005 g
Linearity	±0,02 g
Stabilization time	1,5 s
Adjustment	internal (automatic)
OIML Class	-
Physical parameters	
Leveling system	manual
Display	LCD (backlit)
Protection class	IP 43
Delivery components	Balance, weighing pan, weighing pan shield, power supply
Weighing pan dimensions	195×195 mm
Device dimensions	333x206x107 mm
Packaging dimensions	470×380×336 mm
Net weight	4,5 kg
Gross weight	6,1 kg
Communication interface	
Communication interface	2×RS232 ¹ , USB-A, USB-B, Wi-Fi (option)
Electrical parameters	
Power supply	Adapter: 100 – 240V AC 50/60Hz 0,6A; 12V DC 1,2A Balance: 12 – 15V DC 0,4A max
Environmental conditions	
Operating temperature	+10 ÷ +40 °C
Storage temperature	-20 ÷ +50 °C
Relative humidity	40% ÷ 80%

Repeatability is expressed as a standard deviation from 10 weighing cycles. Stabilization time depends on the ambient conditions and the dynamics of weighing pan loading; specified for FAST profile. 1 Barcode scanners, available as weighing instrument accessory, communicate with the instrument via RS232 interface exclusively.

* Wi-Fi® is a registered trademark of Wi-Fi® Alliance.



Accessories

Balance Storage Case
Barcode scanners
Cigarette lighter receptacle power supply cables
USB cable (scale - printer)

Draft Shield
Protective cover for balances
Receipt Printer
RPANEL BOX

Density determination KIT	RS 232, RS 485 cables
Power Adapters	Under-Pan Weighing Rack
Anti-Draft Chamber for Balances with a 128×128 mm Weighing Pan	RS 232 cables (scale - printer)
Antivibration Tables	Under-pan weighing
Displays	

Software

RAD-KEY	LabVIEW Driver
R Panel	Alibi Reader
R-LAB	RADWAG Development Studio
E2R System	R.Barcode

Device dimensions

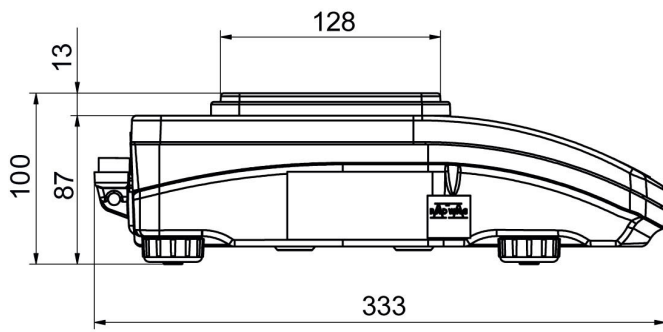

PS R, d = 1 mg

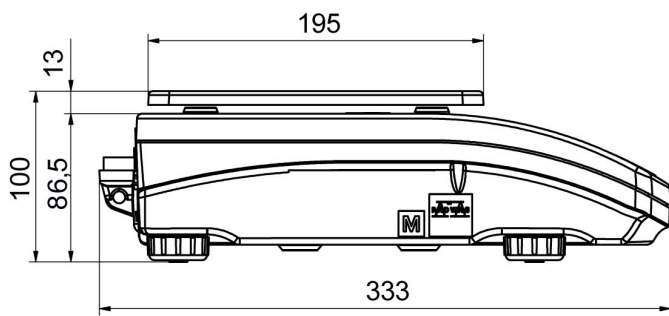
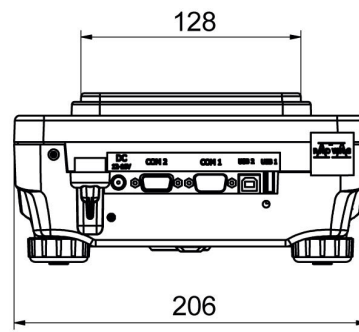

PS R, d = 10 mg

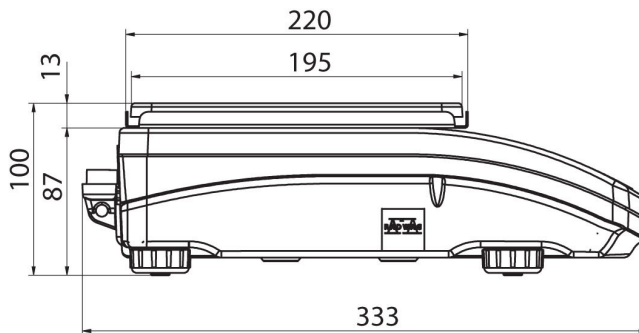
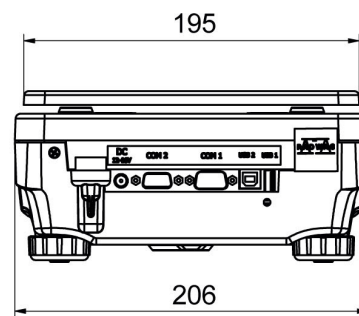

PS R.M, d = 10 mg

